



Instruction manual

JetCat P60 / P70 / P80 / P120 / P180 / P160 / P200



Ing. Büro CAT
M.Zipperer GmbH
Etzenbach 16
79129 Staufen

Tel.: 0049 (0) 76 36 - 78 03 - 0
Fax: 0049 (0) 76 36 - 78 03 - 45
Internet: www.cat-ing.de/turbines

Table of contents

Page

Introduction.....	3
Safety Precautions	4
The Checklist.....	5
Before Running the Turbine	5
After Stopping the Turbine.....	5
Electrical connection diagramm (1/2)	6
Electrical connection diagramm (2/2)	7
Power Supply	8
Charging the Battery.....	8
Glow Plug	8
Fuel / Fuel Care	8
Fuel System.....	9
Hopper Tank.....	9
Fuel System Connection Diagram A.....	10
Fuel System Connection Diagram B.....	11
Fuel System Connection Diagram C (with Hoppertank)	12
Fuelpump adjustment	13
Starting Gas Diagram	14
Filling the Starting Gas Tank:	15
Mounting the Turbine.....	16
Suggested turbine installation	16
Connections at the Turbine	17
The LED I/O Board	18
Aligning the ECU to your R/C System	19
Manual Mode.....	22
Turbine Starting / Running.....	23
Turbine Stopping / Cool Down.....	24
Manual Off	24
Auto Off	24
Automatic Cooling Process	24
Battery / Fuel Warning Function	25
Turbine Running States	25
Explanation of the Turbine States	25
Explanation for Turbine Shut Down	28
Ground Support Unit (GSU).....	29
GSU Control Panel Descriptions	29
GSU Switch Descriptions	30
GSU LED Descriptions	30
Menu Structure	31
Menu Selections	31
Selecting a Menu	31
Change Values / Items.....	31
The RUN Menu.....	32
The Min/Max Menu	32
The R/C Check Menu	32
The INFO Menu.....	33
The Statistic-Menu.....	34
The LIMITs Menu	34
<i>Smoker valve</i>	36
Connection diagram smokesystem	37
Troubleshooting.....	38
Maintenance	39
Parts List.....	40
Optional Accessories.....	40
<i>Airspeed Sensor</i>	41
Ducting	47

Introduction

Welcome to the Jet Age of model aircraft! **CAT** is pleased to sell, support and service the **JetCAT** turbine engine and greatly appreciates your purchase. We hope the **JetCAT engine** brings you many days of pleasurable flying.

Obviously, model turbine aviation - despite all the apparent fun involved - is serious business. The **JetCAT ENGINE** has undergone extensive testing and redesign, in order to ensure it is a safe and reliable model engine; however, it is **not** a recommended power source for the average model builder. It requires a good background in model flying and a working understanding of the principles of turbine engines, along with a disciplined commitment to correct and safe operation, in accordance with these instructions.

To begin, read this manual thoroughly. Develop an overall impression of the engine and its operating procedures, measuring equipment and accessories. Study the material step-by-step and ascertain how to install, operate and maintain your turbine engine. If you are unsure about anything, re-read it again.

DO NOT OPERATE THE *JetCAT engine* BEFORE YOU HAVE READ THE MANUAL AND FULLY UNDERSTAND EVERY PROCEDURAL DETAIL

Should you still have doubts or questions, do not hesitate to contact **CAT** for further assistance.

Once you are accustomed to handling the **JetCAT ENGINE**, you will observe that it is a very reliable engine. Some experienced operators have expressed their belief that it handles better than many piston engines. However, always remember this is a **REAL JET ENGINE**, requiring knowledge, discipline and maintenance.

In order to learn more about the development of the model turbine engine and understand its function, we highly recommend reading **Gas Turbine Engines for Model Aircraft** by Kurt Schreckling and **Model Jet Engines** by Thomas Kamps. These books are available through:

Traplet Publications

Traplet House

Severn Drive

Upton upon Severn, Worcestershire

United Kingdom WR8 0JL

ISBN 0 9510589 1 6

ISBN 0 9510589 9 1

Safety Precautions

If other persons or animals are present while operating the **JetCAT ENGINE**, **ALWAYS ENFORCE THE PROPER MINIMUM SAFE DISTANCES FROM THE TURBINE!**

The recommended minimum safe distances are:

In front of the turbine	= 15 feet
On the side of the turbine	= 25 feet
Behind the turbine	= 15 feet

In case of a mishap, fire extinguishers should be on hand at all times. **CAT** recommends the CO/2 variety. Powdered extinguishers will contaminate the precision components, upsetting the integrity of the turbine.

To avoid hearing damage, always use hearing protection when you are near a running turbine engine!

When the turbine is running, never place your hands closer than six inches into the area of the intake. An **extreme** suction - which can grasp a hand, fingers or other objects in a flash - prevails in this area. Be aware of this source of danger, always!

Prevent foreign materials from entering the intake or exhaust when working with the turbine. Before operation, make sure there are no loose parts or debris near the turbine. Objects being sucked in can cause severe damage.

Always exercise caution around the hot parts of the turbine, to avoid burns. The outer case at the turbine stage and nozzle reaches 450-500° (Celsius), while the exhaust gas may exceed 720 ° C.

Assure that the fuel is mixed with approximately 5% synthetic oil. Use only synthetic turbine oils available at local airport fuel suppliers or from **CAT**.

Never run the turbine in a closed room, or an area near any kind of flammable matter. Do not fly turbine-powered aircraft near flammable materials, nor in forested tracts or areas experiencing drought or dryness. Obey all forest fire regulations and warnings by refraining from operating the **JetCAT ENGINE** in restricted fire zones. Never operate model turbine jet aircraft in or around residential or heavily populated areas.

After running the turbine, briefly point the nose upward to assure that there is no fuel left in the engine.

Installation of unauthorized parts from another manufacturing source may also result in engine failure. Do not introduce engine or electronic components other than those delivered by **CAT**, unless you are willing to risk destroying your turbine! **CAT'** parts are designed and engineered specifically for the **JetCAT P80/ P120**. Accept no substitutes, unless you are prepared to sacrifice your aircraft.

Warning:

A flying model with a turbine can reach higher flight speeds than ducted fan-powered models, because the turbine's thrust degrades less with higher flight speeds. With attainable flight speeds of over 250 MPH, you can quickly run out of flying room. There is also a danger of developing control surface flutter or mechanical overload, causing the model to fail in flight. When piloting a turbine powered aircraft, one must properly control the throttle. Full power should be used for takeoff or vertical maneuvers and a reduced setting for level or descending flight. To restrict the maximum flight speed, an optional airspeed sensor is available.

The Checklist

Before Running the Turbine

- Charge ECU Battery
- Prepare fire extinguisher
- Check fuel lines and filter. Make sure they are clean with no restrictions
- Check that the fuel tank vent is unobstructed
- Mix 5 % oil in fuel (i.e.: 1 quart per 5 gallons of kerosene)
- Fill fuel tank(s). Make sure the main and header tanks are full
- Be certain the starting gas release valve is closed, before filling the starting gas tank
- Turn on receiver switch
- Place the model with nose into the wind
- Activate brakes and start turbine

After Stopping the Turbine

- Turn model into the wind. Activate brakes and stop turbine
- After the cooling process (approximately two minutes), turn off receiver switch
- After each flying session, open starting gas release valve, to empty the tank, before storing the model. This should be executed in a safe area

Electrical connection diagramm (1/2)

Connection - diagramm (Verbindungsschema)

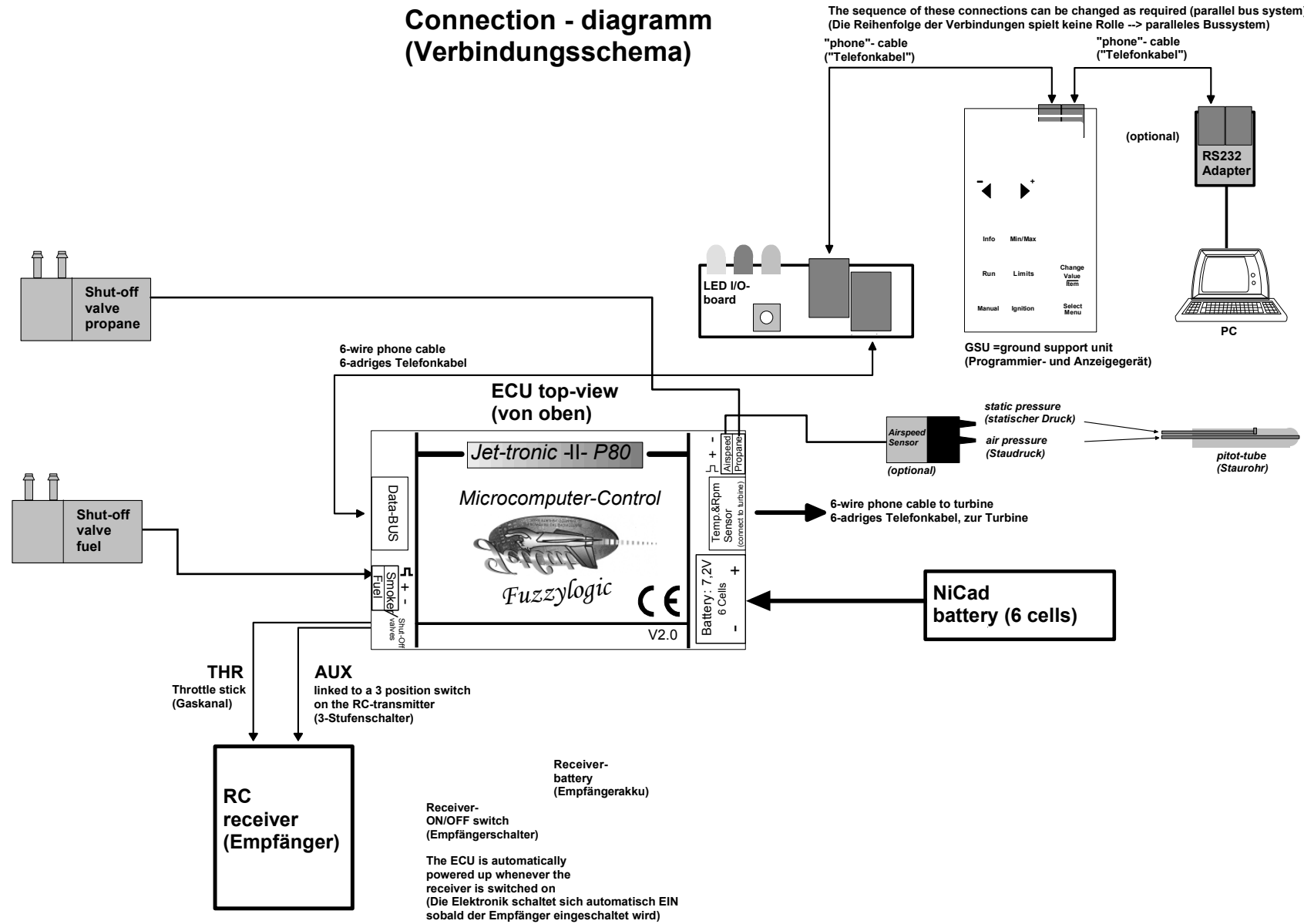

Electrical connection diagramm (2/2)

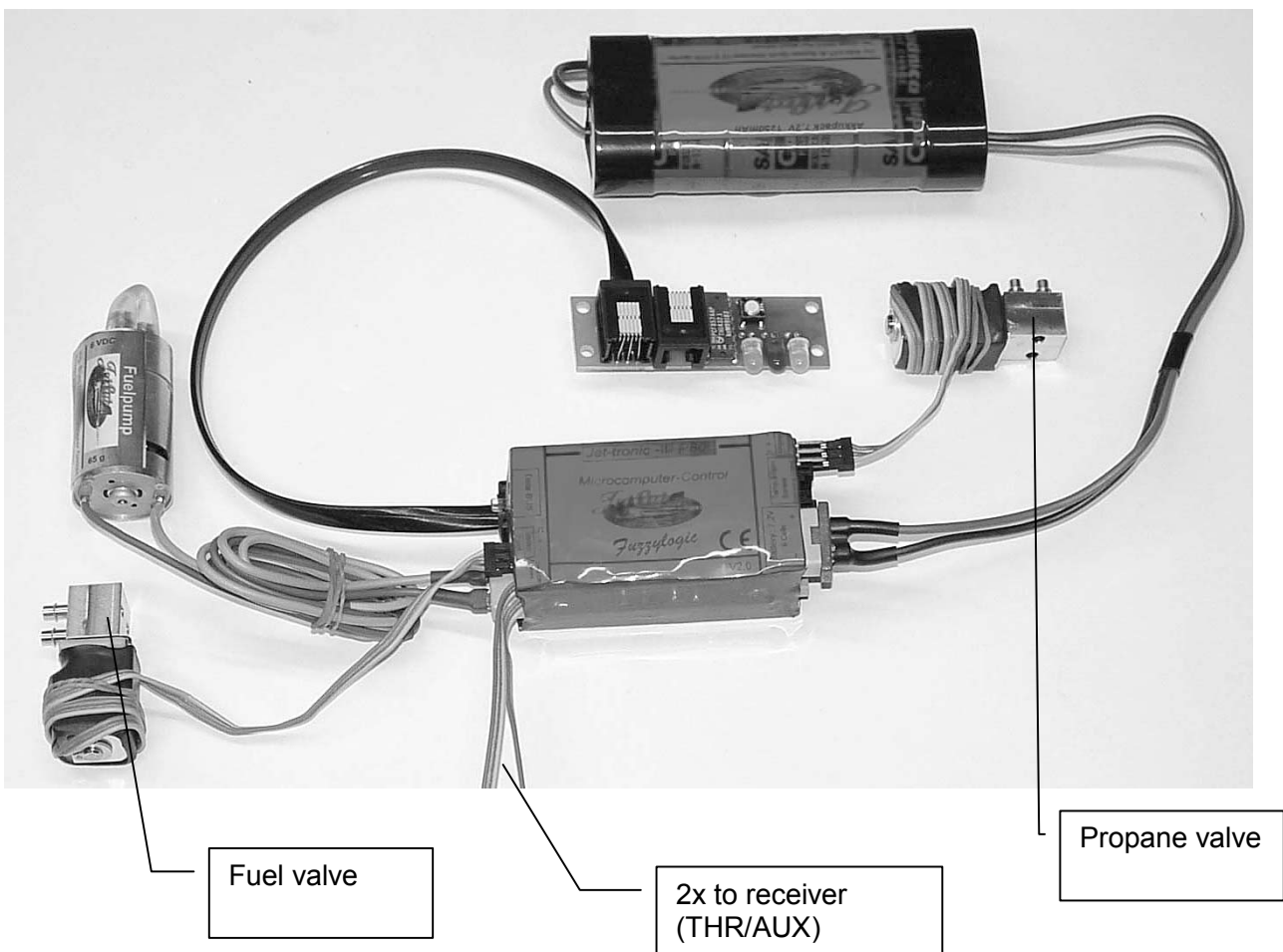
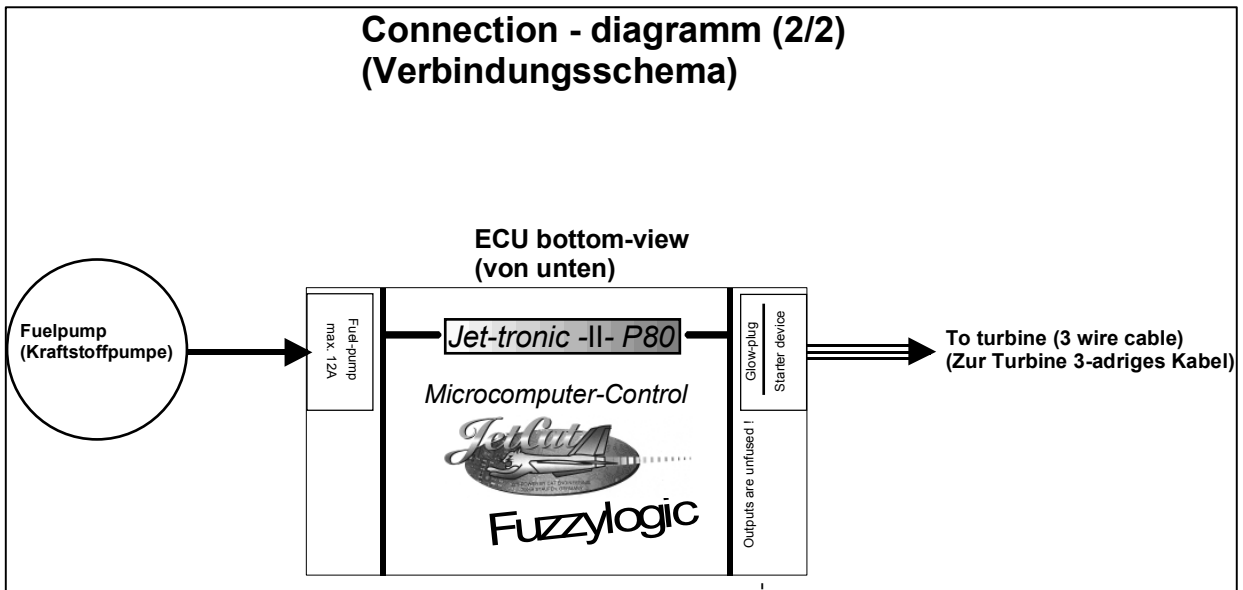



Fuelvalve to be connected on lower output

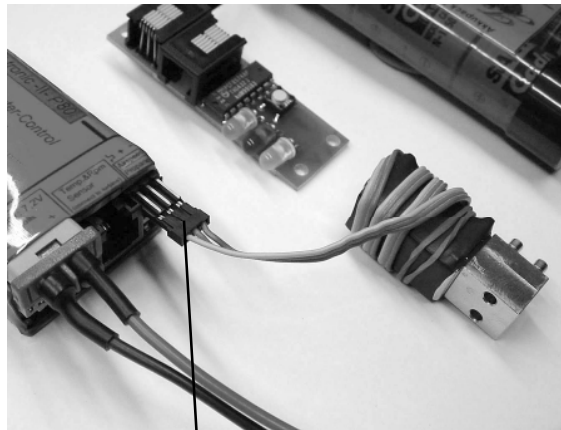

Propane valve (below AirSpeed input.)

Power Supply

Power for all electrical components of the turbine (starter / glow plug / ECU / fuel pump / fuel and gas valves) are supplied by the six-cell, 1250 mah ECU battery. The amount of battery capacity used per flight is approximately 300-400 mah. This includes starting and cool down. The ECU NiCad battery **must** be recharged after three (3) flights! **CAT** recommends recharging after every flight, making it a routine that is not overlooked. The battery should be cycled periodically, to prevent NiCad memory problems that lower the battery's capacity.

Charging the Battery

Do not charge the battery, with a quick charger using negative discharge pulses, when connected to the ECU. This will destroy the electronics of the ECU. The only recommended method is to disconnect the battery from the ECU and charge it directly.

If you are absolutely sure that this is not the case with your charger, the battery can be charged using an Y cable.

Glow Plug

A modified, conventional (hot range, non-idle bar) glow plug (Rossi #3) is appropriate. The glow plug is installed on the turbine without a washer. Do not over-tighten or you may damage the threaded bushing. Light torque is fine; there is no vibration to loosen it. The glow plug is modified, so that two turns of the element extend beyond the bottom of the plug. With a pin, pull out two turns of the element. Make sure the plug glows brightly red. The limits menu features an adjustment for glow plug voltage, if needed. This adjustment is described later.

Fuel / Fuel Care

The **JetCAT** engine can use deodorized kerosene, 1-K kerosene or Jet-A1 for fuel. Fuel must be mixed with 5% synthetic turbine oil.

Example formula: 1 quart of oil in 5 gallons of fuel.

Oil brands like Aeroshell 500 or Exxon 2380 are suitable.

Fuel System

The input and output fuel tubing must be connected to the electronic shut-off valve as per the drawing. The fuel in is towards the heat shrink tubing covered coil. The fuel out is towards the edge of the valve. **It will not shut off if connected incorrectly!**

If a header tank is used, the clunk is placed in the main tank. Otherwise, place the clunk in the last tank before the fuel valve.

When installing the fuel lines on components with nipples, slightly warm the tubing before connecting. This will soften the tube, making it easier to install. When installing tubing on a metal tube, secure the tubing by placing a tie-wrap around the connection. To remove tubing from nipples, you must cut the tubing off. Be careful not to damage the nipple when cutting off tubing. To insert tubing into Festo quick release fittings, use firm pressure until you feel the tube snap in. To release, press in on the front ring, while pulling the tubing out.

ALWAYS use a gasoline-compatible stopper. Silicon stoppers swell and leak.

Check your fuel filters every ten (10) flights. You may be surprised how rapidly they can clog up!

The filter is installed with the **O-ring located toward the fuel shut-off valve.**

When running the engine at full power, check the fuel line from the pump to the engine. If there is a large quantity of air bubbles flowing with the fuel, there is probably a restriction in the fuel system or an air leak in a fitting.

Hopper Tank

A hopper tank is recommended, between the main fuel tank and the engine. Using a hopper tank lessens the possibility of air bubbles in the fuel system, thus reducing the risk of a flameout. The hopper tank should accommodate approximately four (4) ounces and the fuel pickup should be a brass tube, positioned in the center of the tank. Do not use a clunk.

Fuel System Connection Diagram A

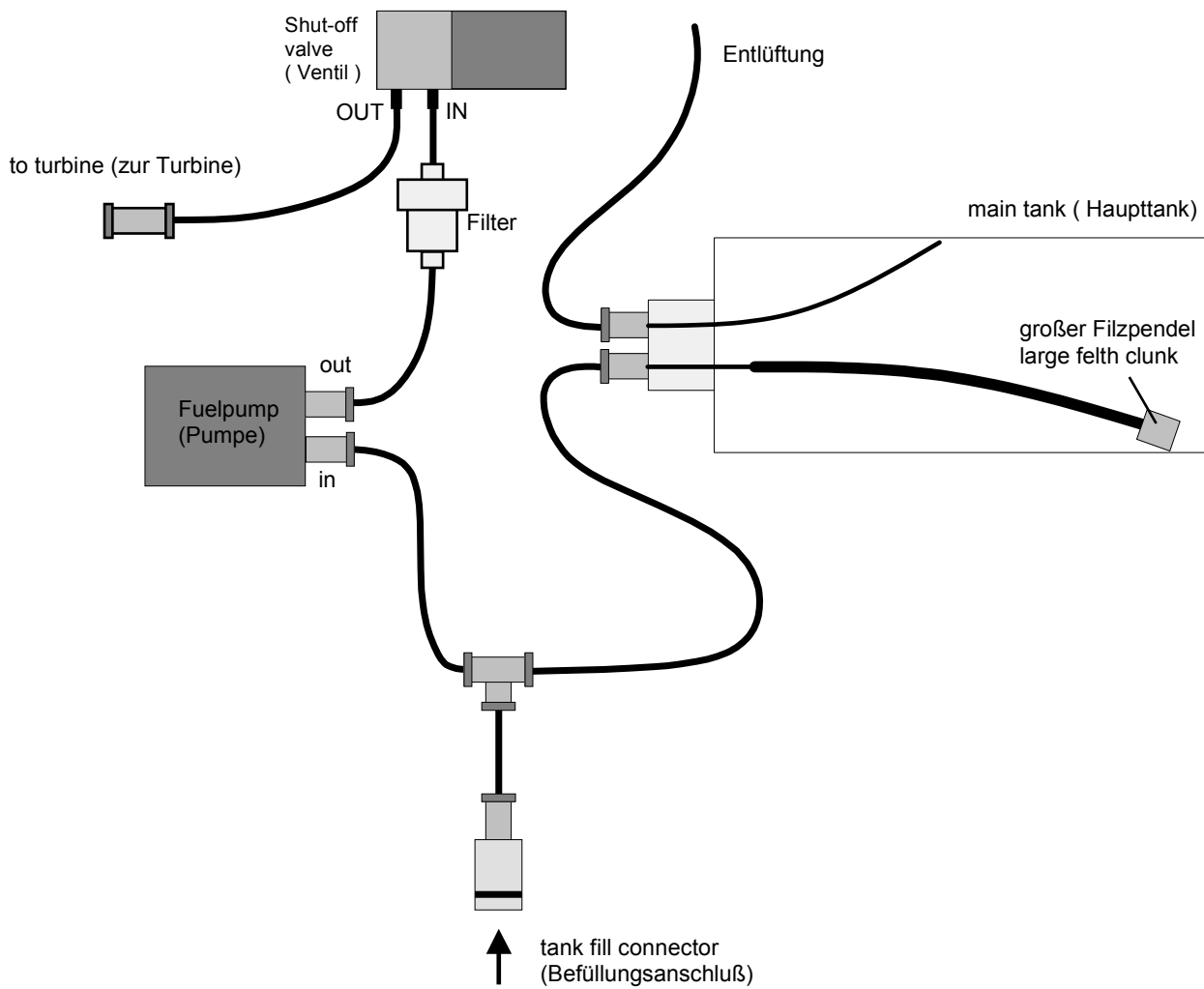

Fuel System Connection Diagram B

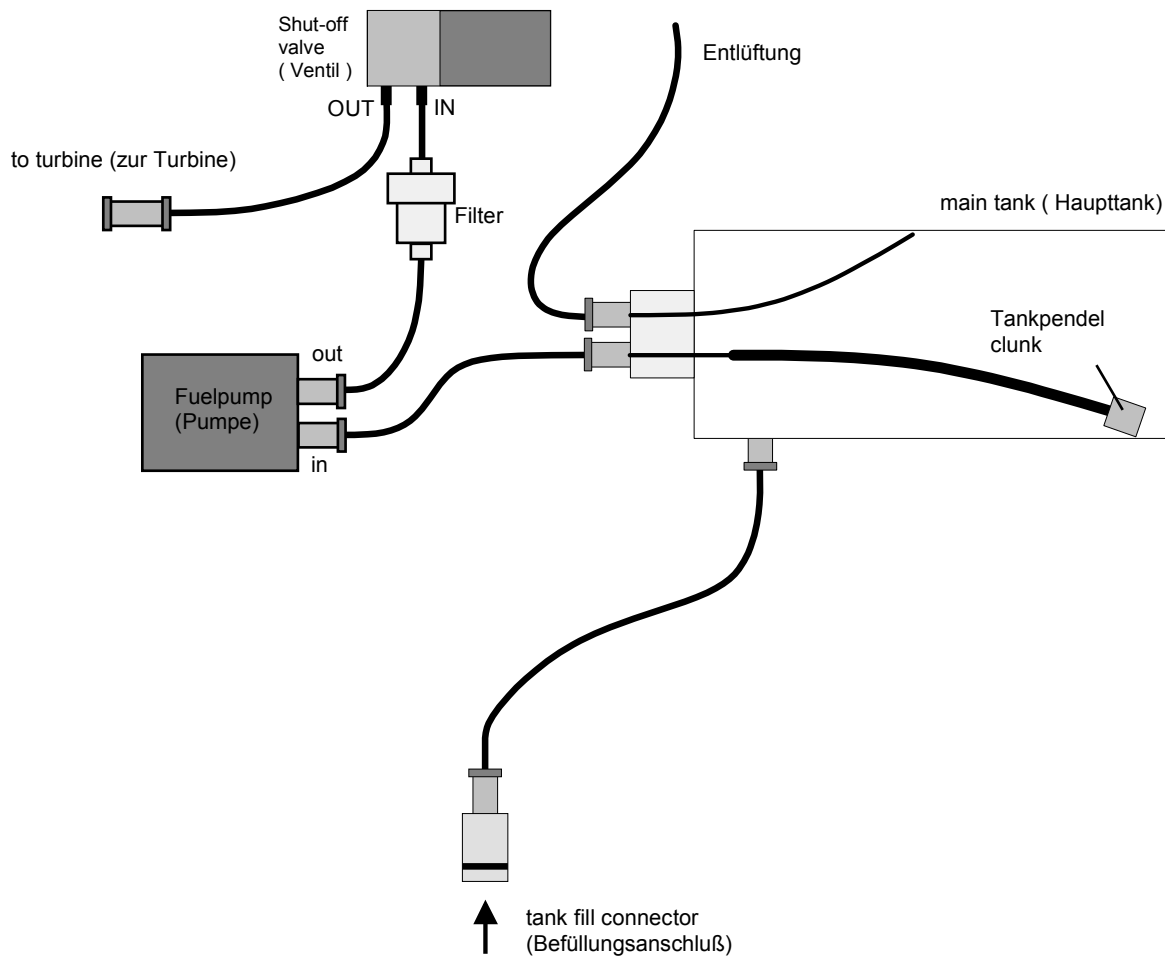

Fuel System Connection Diagram C (with Hoppertank)

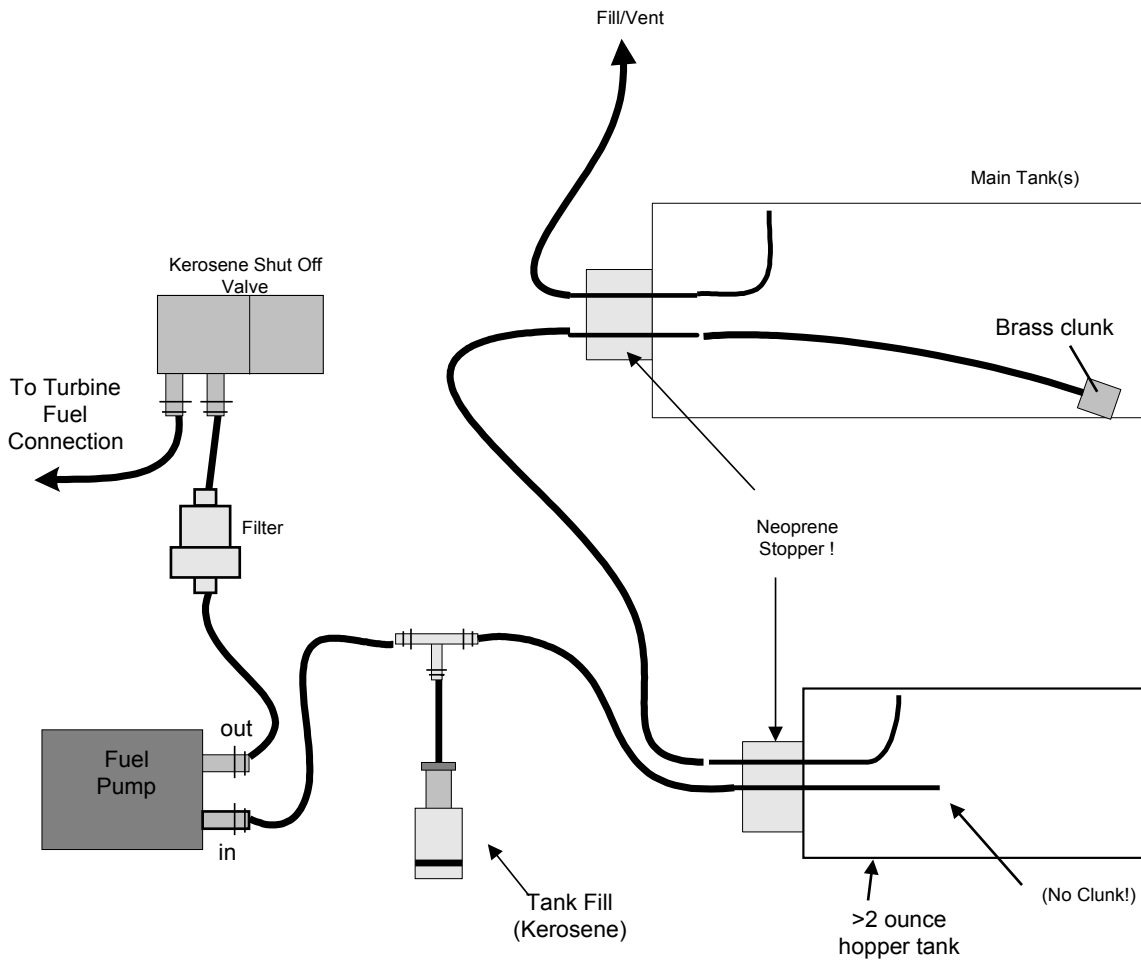

Note: All tubing 4mm

Fuelpump adjustment

After the turbine has ignited on propane, the turbine is further accelerated by the starter motor. At approx. 5000 1/min the fuelpump is automatically started at minimum power by the ECU. Beginning from this first pump start voltage, the fuelflow is then slowly increased by increasing the pump voltage.

The initial pump voltage with which the pump is supplied immediately after ignition has been factory adjusted. After exchange of the fuelpump or after several turbine runs (pump has "runned in" → pump is turning more easy → pump is delivering too much fuel at startup → long flames behind the turbine exhaust) it might be necessary to readjust the pump start voltage.

For adjustment of the pump start voltage, the ECU incorporates a special adjustment function which can be accessed as follows:

1. Interrupt fuel supply to the turbine. If the fuel supply to the turbine is not disconnected/interrupted the turbine can be "filled" with fuel during the following adjustment procedure !!! → Danger of a "Hot Start"
2. Switch off ECU and plug in GSU (RC transmitter is not being used)
3. Press and hold the key „Change Value/Item“ on the GSU and switch on the ECU
4. Release the „Change Value/Item“ when the display of the GSU shows the following:

```
Pump start volt.  
Uaccelr1:
```

The pump start voltage can now be tested by pressing the „RUN“ button.

To increase the pump start voltage by one increment press the "Min/Max" button.

To decrease the pump start voltage by one increment press the "Info" button.

The pump start voltage should now be adjusted in such a manner, that the pump just securely starts to turn, and that the fuel is delivered in a thin fuel stream (a little bit more than just dropping out of the tubing). To test this, press the "Run" button several times to check that the pump starts securely running on different pump rotor positions.

Normal values for the pump start voltage are between 0.1 and 0,25V (default: 0,2Volt)

Important:

At the end of the adjustment procedure press the "Manual" button to store the new setting and resume to normal operation.

Pump start voltage is adjusted too low:

If the pump start voltage is adjusted too low it can happen, that the pump is not starting to turn because of a too low supply voltage (→ the red "pump running" LED is illuminated but the pump is not turning). This can result in that the turbine after ignition on propane runs a unusual long time on propane not picking up RPM as no fuel is delivered. If this time is too long (>10sec.) the ECU will terminate the start and show the Error message „AccTimOut“ or „Acc. Slow“ (=acceleration too slow).

Pump start voltage is adjusted too high:

If the pump start voltage is adjusted too high the turbine is supplied with too much fuel at start up which then can result in heavy flames behind the turbine at start up (→ turbine RPM too low compared to fuel supplied)

Filling the Starting Gas Tank:

Only use a propane/butane mix for starting gas. **CAT** recommends **Coleman POWERMAX** fuel (or a mix of propane butane 60/40%). **POWERMAX** is available at sporting goods stores or from **CAT**. Use the 10.6-ounce size.

Do not use 100% propane from torch refill bottles. The pressure is too high and will cause the tubing to rupture.

To fill the tank, connect the fill connector of the gas refill bottle to the selfshutting connector starting gas tank in the model. Put the **POWERMAX** fuel can upside down, then open the valve at the refill bottle (→ liquid gas is flowing into the starting gas tank) Verify that the fluid is flowing into the tubing. Continue filling, until the fluid slows or stops. Just before the liquid stops flowing put the refill bottle back to the upright position. Although several starts are attainable with a full tank, **CAT** recommends refilling before every flight, establishing a routine that is not overlooked.

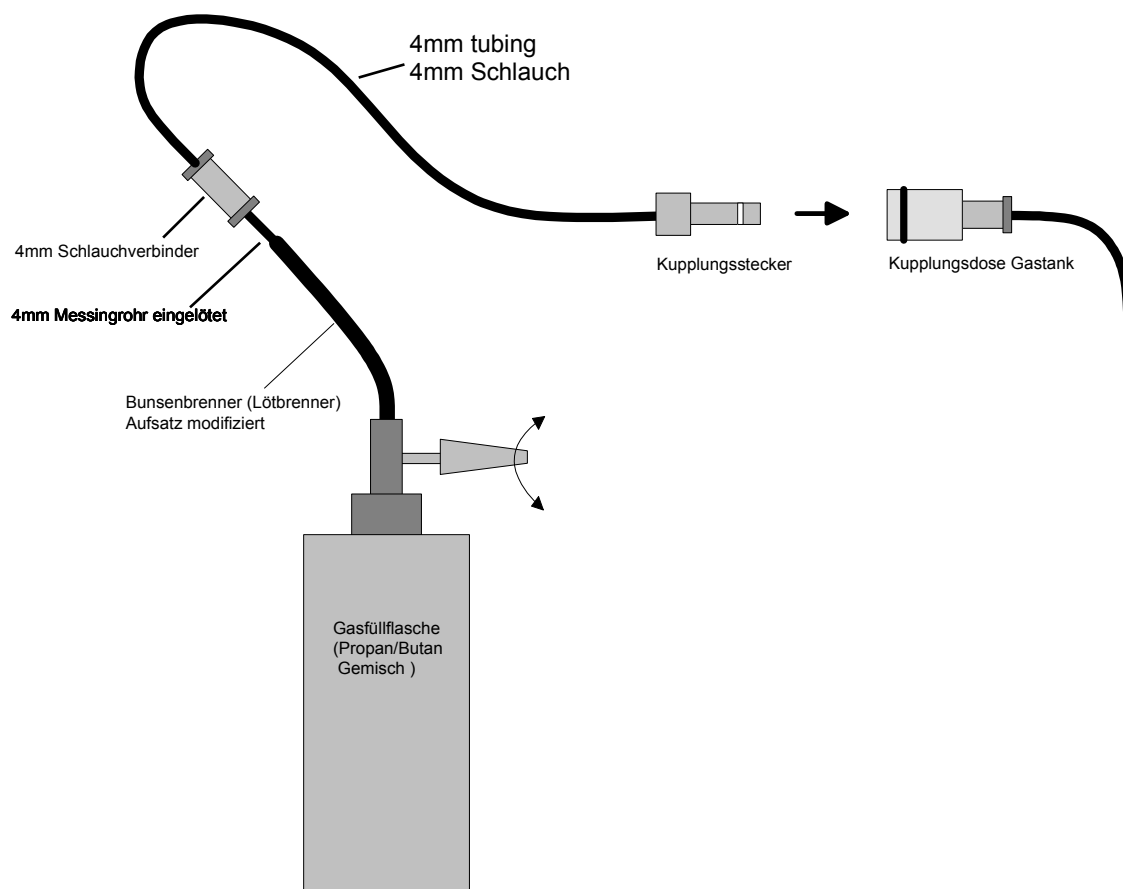

Mounting the Turbine

A two-piece, aluminum mounting bracket is included with the turbine. Place the bracket around the turbine, with the glow plug situated within the slot of the smaller bracket piece. This will help stabilize the engine along the thrust axis. The glow plug must be in the vertical position, when mounted in your model (+/- 45° of engine rotation, from the glow plug at top dead center, is the allowable deviation). Secure the engine, using four metric mounting screws and lock washers that are provided with brackets.

For models that require an exterior turbine mount (such as the Kangaroo) or for bypass tube mounting, optional brackets are available from **CAT**.

Suggested turbine installation

Turbine side view / thrust tube

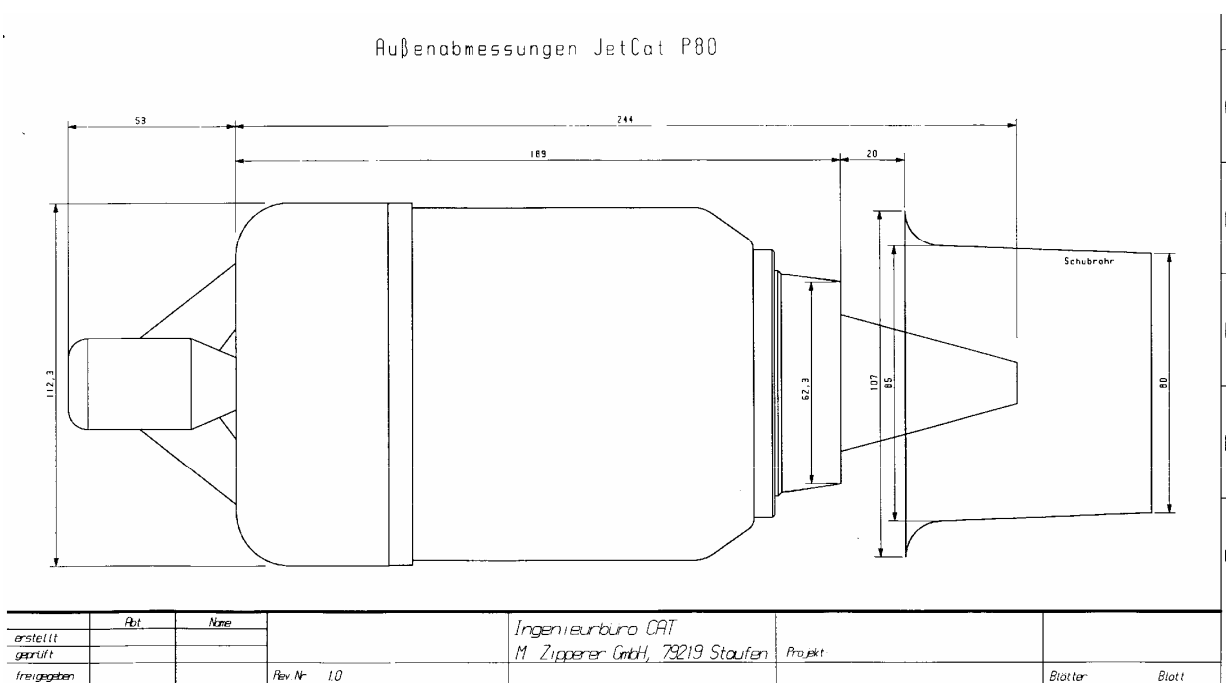

When the turbine is mounted in models with the air intake at the bottom, for example F-16, care should be taken to prevent foreign object damage of the compressor stage. This can be accomplished by using a strainer screen at the inlet. The screen mesh should be about 0.02 to 0.06 inches in width.

Connections at the Turbine

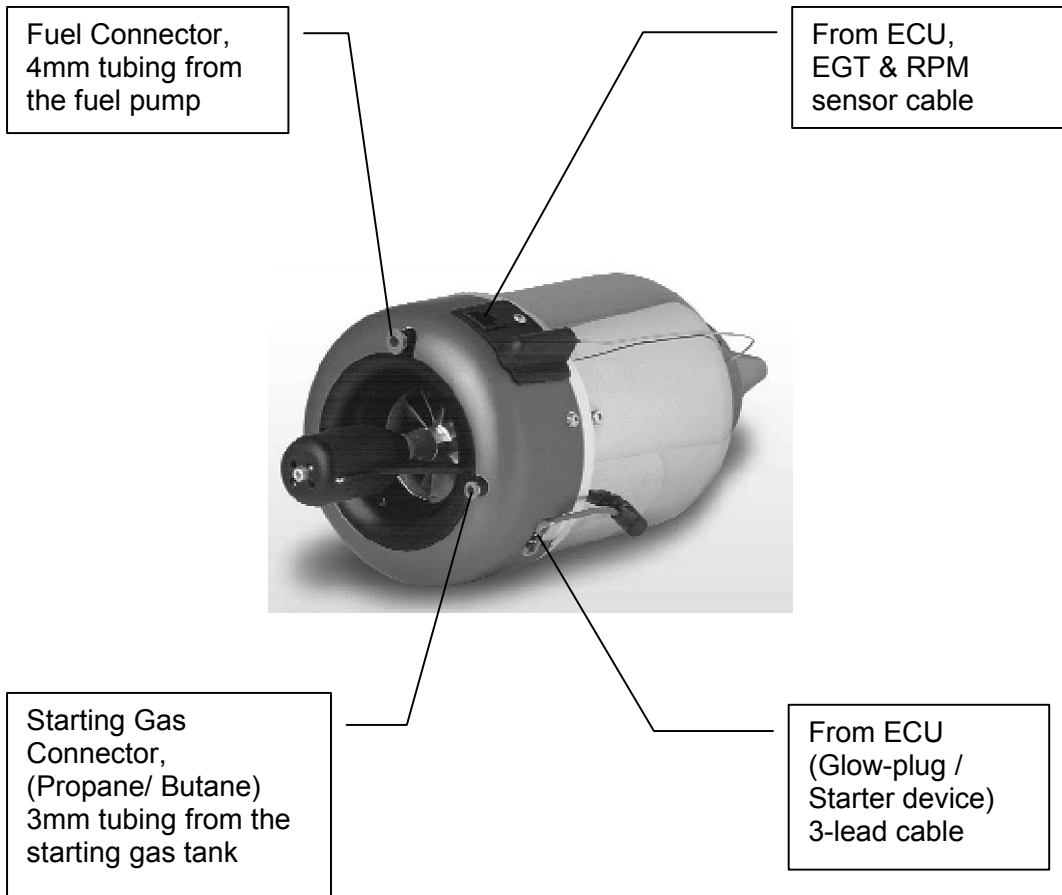

The LED I/O Board

The LED I/O (Input/Output) board is a connection point for the data bus and a display for the current status of the ECU. The board should be mounted with the LED's visible and the data bus connector accessible for GSU plug-ins. The connector facing opposite of the LED's is attached to the ECU. The LED I/O board also features a pushbutton switch function - to learn your R/C system (when powered up), or for entering the MANUAL mode (when power is already on). These procedures are described later.

Illustration 1:

Explanation of the Lights on the LED I/O board. These LED indicators are identical to the **GSU** LED's (excluding the red "ignition on").

Color	Name	LED On	LED Blinks
Yellow	Standby	Starter Motor engaged	Manual Mode is active
Red	Pump Running	Fuel pump is on	Glow Plug is defective
Green	OK / Reset...	Turbine running: throttle control active	1. If the turbine is running, the EGT is exceeding the maximum temperature. 2. If the turbine is off, SlowDown mode active

Special function:

If the yellow **Standby/Manual** and green **OK** LED's blink simultaneously, the battery is low and must be recharged.

Aligning the ECU to your R/C System

Before the Jet-Tronic ECU can be used for the first time, throttle stick and auxiliary control positions must first be programmed.

To accomplish this, complete the following steps:

1. Connect the two ECU servo cables to the receiver. The “**THR**” cable connects to the throttle channel and the “**AUX**” cable must be connected to a channel capable of three (3) positions. Make certain that all other connections are made in accordance with the **Electrical Connection Diagram**.
2. Inspect the transmitter programming, to ensure that dual rates and exponential functions are disabled, travel is set at 100% and sub trim is set at zero for both channels.
3. While pressing the “**Select Menu**” button on the GSU, switch on the receiver.

Helpful hint:

Instead of the **Select Menu** button on the GSU, the small switch on the LED I/O board may be pressed instead. This button can also be used to advance through the “**learn R/C**” sequence (described below). This feature is useful when the GSU is not available. Keep in mind that the LED’s on the I/O board are the same as the GSU for “**Standby/Manual**”, “**Pump running**” and “**OK**”.

Release **Select Menu** only after the three LED’s display the following blink sequence:

LED	Blink Sequence
Standby/Man.	Yellow ● ○ ○ ○ ● ○ ○
Pump running	Red ○ ⇒ ● ⇒ ○ ⇒ ○ ⇒ ● ⇒ ○
OK	Green ○ ○ ● ○ ○ ●

The GSU display will simultaneously read:

Release key to:
- learn RC -

4. This procedure enables a system mode, whereby the stick positions can be learned by the ECU. When **Select Menu** is released, only the green **OK** LED should illuminate.

The GSU display will read:

Set Throttle to
minimum:

→ Alternate “**Off**” position

5. Now the ECU can memorize the positions of the throttle and AUX channels. First, place the throttle stick and throttle trim to low. Next, press **Select Menu** or the LED I/O board switch, again. This will store the R/C system’s pulse width for immediate shutdown of the turbine. The green **OK** LED will turn off and the red **Pump running** LED will illuminate. This indicates that the shutdown data has been set correctly.

The GSU display will read:

Throttle Trim
to maximum:

→ Throttle channel “**Idle**” position

6. Advance the throttle trim lever to maximum. Press **Select Menu** or the LED I/O board switch again, to store the R/C system’s pulse width for the turbine idle position. The red **Pump running** LED will turn off and the yellow **Standby/Manual** LED will illuminate. This indicates that the turbine idle data has been set correctly.

The GSU display will read:

Set Throttle to
maximum:

→ Throttle channel “**Full Power**” position

7. Advance the throttle stick to maximum. Press **Select Menu** or the LED I/O board switch again, to store the R/C system’s pulse width for the turbine full power position. The yellow **Standby/Manual** LED will turn off and the green **OK** LED will illuminate again, indicating that the turbine full power data has been set correctly. This completes the learn mode for throttle and initiates the learn mode for the three-position AUX channel.

The GSU display will now read:

Set AuxChan. to
MINIMUM:

→ AUX channel minimum “**Off**” position.

8. Move the AUX channel to the minimum position for **Off** and press **Select Menu** or the LED I/O board switch again, to store the R/C system’s pulse width for immediate shutdown of the turbine. The green **OK** LED will turn off and the red **Pump running** LED will illuminate. This indicates that turbine shutdown data has been set correctly.

The GSU display will read:

Set AuxChan. to
CENTER:

→ AUX channel middle “**Start/Standby**” position

9. Set the AUX channel to the middle position for **Start/Standby** and press **Select Menu** or the LED I/O board switch again, to store the R/C system’s pulse width for the turbine to start and run. The red **Pump running** LED will turn off and the yellow **Standby/Manual** LED will illuminate. This indicates that the turbine start/standby data has been set correctly.

The GSU display will read:

Set AuxChan. to
MAXIMUM:

→ AUX channel maximum “**Auto-Off**” position

10. Place the AUX channel on the maximum position for **Auto-Off** and press **Select Menu** or the LED I/O board switch, to store the R/C system’s pulse width for a normal shut-off of the engine. The yellow **Standby/Manual** LED will turn off and the ECU will now permanently store the data. This indicates that the “**learn R/C**” procedure is completed and the ECU now retains the pre-set stick position values. Repeating this procedure is only necessary when the R/C system is changed or adjusted.

Manual Mode

During normal ECU function, the operator has no direct control of the fuel pump or fuel shutoff valve. To prime the fuel pump and fuel lines (or for fuel pump test purposes), it is necessary to open the fuel shutoff valve and run the fuel pump manually. For this purpose, the ECU has a special feature that opens the fuel valve and acts as a speed control for running the pump.

Extremely Important:

Manual mode allows the fuel pump to operate without the turbine running. However, if the fuel feed line is not removed from the turbine during this procedure, it will become flooded with fuel. When this occurs, the next turbine start can become highly combustible!

Before activating the manual mode, ALWAYS remove the fuel feed line connected to the turbine.

To activate manual mode, the AUX switch must be **Off** and the throttle stick and trim to their minimum positions. All LED's will be off. Manual mode can now be activated by pressing the GSU **MANUAL** button or by pressing the small switch on the LED I/O board. When manual mode is active, the yellow **Standby/Manual** LED will blink and the fuel shutoff valve opens. Move the AUX switch to the **Start/Standby** (middle) position, and the throttle stick can then actively control the fuel pump. Returning the throttle stick to its idle position will stop the fuel pump.

In manual mode, by placing the AUX switch in the **Auto-Off** position, the throttle stick will work as an on/off switch for the fuel pump. When the throttle stick is advanced from idle, the fuel pump will run at a steady pre-programmed speed – the minimum setting that will reliably run the pump. If the throttle stick is returned to idle, the pump will shut off. During startup, this speed is used to establish initial voltage for the fuel pump.

Manual mode may be disengaged by two separate methods:

- Press the **MANUAL** button on the GSU or the LED I/O board switch, a second time.
- By repositioning the AUX switch back to its **Off** setting.

The yellow **Standby/Manual** LED will stop blinking!

Turbine Starting / Running

1. Prepare to start by completing the startup checklist (previously described on **page 5**).
2. Briefly hold the model upward, to ensure there is no residual fuel in the turbine.
3. Set the AUX switch to the **Off** position. All LED's will be off.
4. Move the throttle trim lever to idle (maximum) position.
5. Set the AUX switch to the **Start/Standby** (middle) position.
6. If the throttle stick is not at the idle position, the LED's will blink in a continuous sequence of yellow to red to green. Bring the throttle stick to the idle position, changing the LED blink sequence to green to red to yellow, continuously. The turbine is now ready to start!
7. Advance the throttle stick to its maximum setting and the turbine will start.
8. Once the turbine begins to accelerate, the throttle stick can be returned to idle position. As soon as the turbine stabilizes at idle speed, the green **OK** LED will illuminate, indicating that thrust control is now handed over to the pilot. The throttle stick must be in the idle position, for the green **OK** LED to illuminate.

When the throttle stick is set to the maximum position (Step 7 above), the ECU will begin a fully automatic starting sequence. This starting sequence can be immediately disengaged, by moving the AUX switch to the **Off** position.

After the start process is initiated, the following occurs:

1. The starting motor spins the turbine rotor up to approximately 2,500-3,500 RPM -then the starting motor is stopped.
2. Next, the glow plug is switched on and the starting gas valve opened.
3. The speed of the turbine begins to fall slowly, while ignition normally occurs during this period. Should ignition not occur, the starter will automatically make more attempts. If the turbine does not ignite, during a 30-second period of attempts, the process is aborted and the green **OK** LED will blink.
4. As soon as ignition occurs, the yellow **Standby/Manual** LED will illuminate and the starting motor is re-engaged to accelerate the turbine. At approximately 5000 RPM, the fuel pump switches on and the red **Pump running** LED illuminates.
5. Turbine speed will progressively increase until achieving stable speed. When the turbine speed surpasses the idle RPM value, the starter motor disengages and the yellow **Standby/Manual** LED goes out.
6. As the turbine approaches approximately 55,000 RPM, it will briefly stabilize, before automatically decelerating to idle RPM.
7. When the turbine attains idle speed and the throttle stick is placed at idle position, the green **OK** LED will illuminate, indicating that thrust control is now handed over to the pilot.

Turbine Stopping / Cool Down

To shut off the turbine, there are two methods:

Manual Off

Turbine immediately turns off!

At anytime, the turbine can immediately be switched off manually by:

- setting the three-position AUX switch to **Off**

OR

- bringing the throttle stick to idle position, while bringing the throttle trim to its minimum position

Auto Off

Turbine automatically turns off!

This is the normal way of shutting down the turbine:

When the three-position AUX switch is moved to the **Auto-Off** position, the following happens:

The turbine automatically stabilizes at around 55,000 RPM, for approximately six (6) seconds, before shutting down. This allows the turbine to run at an optimal temperature, drawing in a large quantity of cool air through the turbine, as it shuts off. This automatic off function can be discontinued at any time, by returning the AUX switch back to the **Start/Standby** position, before the turbine shuts down.

Automatic Cooling Process

After the turbine spins down from **Auto Off** or **Manual Off**, the starter motor will periodically spin the turbine rotor, if the **Exhaust Gas Temperature** is above 100° C. This happens at regular intervals, for about one minute or longer.



Extremely Important:

In unsafe situations (e.g.: a model fire), the automatic cooling process may contribute dangerous, additional oxygen. To immediately discontinue the cooling process, bring the throttle stick to idle, throttle trim to the minimum position and the AUX switch to **Off**.

Battery / Fuel Warning Function

The ECU has an optional function for low battery and fuel warning. This function is activated by the following conditions:

1. ECU battery is dangerously low (less than 1.1V/cell).
2. Calculated remaining fuel in tank is below a pre-programmed limit.

When the corresponding warning functions have been enabled in the Limits menu (see page 34), the following occurs:

If the throttle stick is set above 50% thrust, the turbine will idle for five (5) seconds, then return to the actual throttle stick position power for ten (10) seconds. Thereafter, the sequence is repeated.

This warning function can be interrupted for a 25-second period, by briefly bringing the throttle stick to idle and then back to the previous position. As long as the stick is below the 50% throttle level, the warning function will be interrupted. When the throttle stick is set above the 50% level, it returns to the warning function sequence.

Turbine Running States

The **JetCAT turbine** progresses through several operating states, from ignition to the cool down process. The transitions of these states are automatically controlled by the ECU and by user commands. The current value is always displayed on the GSU, under the **STATE** selection in the **RUN** menu.

Explanation of the Turbine States

Table 1

Value	Explanation
-OFF-	AUX switch in the Off position and/or the throttle trim in the Off position. All LEDs are off. Turbine is off (preventing starting).
Stby/START	AUX switch positioned to the Start/Standby position, throttle trim at maximum and throttle stick at idle. The LED chase sequence is started from green to red to yellow, continuously. When throttle stick is advanced to the maximum position, the starter motor engages to spin the rotor. When RPM reaches a pre-programmed value, the starter motor's voltage is removed and the turbine is ready to ignite .

Ignite...	<p>Glow plug is switched on and the starting gas valve is opened. The GSU's red Ignition LED is illuminated when the glow plug switches on.</p> <p>The ECU now pauses until ignition occurs and will remain in this condition until at least one of the following criteria is met:</p> <ul style="list-style-type: none"> • The measured EGT exceeds a pre-programmed value • The measured EGT rises faster than a pre-programmed time <p>If one of these conditions exists, turbine proceeds to the next operant condition (AccelrDly).</p> <p>If the turbine doesn't ignite after several attempts (within the pre-programmed time), the ignition state is discontinued and the turbine will shift to the SlowDown state.</p>
AccelrDly	<p>Voltage for the starter motor is re-engaged. Fuel valve opens and the fuel pump will run at a steady minimum voltage (a level where the pump just begins to operate), for approximately two (2) seconds. During this state, the turbine operating system purges air from the pump and fuel lines, while warming the combustion chamber in preparation for acceleration.</p> <p>Glow plug turns off.</p> <p>The red Pump running LED turns on and will stay illuminated as long as the pump operates.</p>
Acceler.	<p>In this condition, the fuel pump and starter motor voltages ramp up to accelerate the turbine to idle. The yellow Standby/Manual LED will illuminate during this period.</p> <p>Starting gas is shut off.</p> <p>Under normal circumstances, the turbine will ascend to idle RPM. The starter motor then disengages and the yellow Standby/Manual LED turns off. Here, the turbine progresses to the next state (Stabilize).</p> <p>During the following error conditions, the acceleration is discontinued and a jump to the SlowDown state occurs:</p> <ul style="list-style-type: none"> • Turbine does not reach idle RPM after a pre-programmed period of time • The change in turbine speed is less than a pre-programmed amount, during a 0.1 second interval
Stabilize	<p>Turbine successfully accelerates to the idle RPM, then automatically increases speed to about 55,000 RPM. When this speed is maintained consistently for at least one second, the turbine will proceed to the next state (LearnLO).</p>
LearnLO	<p>In this state, the turbine automatically decreases RPM to the idle speed. As soon as idle speed is attained, with the throttle stick in the idle position, the turbine will proceed to the next state (RUN (reg.)).</p>

RUN (reg.)	<p>Turbine in the normal running state; the throttle stick will regulate turbine thrust.</p> <p>During this operant condition, the green OK LED will illuminate, indicating that pilot has control.</p> <p>RUN (reg.) continues, until the turbine is switched off.</p>
AutoOff	<p>The AUX switch placed in the AutoOff position.</p> <p>Turbine automatically adjusts to 55,000 RPM and remains at that RPM for approximately six (6) seconds, before transition to the next state (SlowDown).</p>
SlowDown	<p>During this state, the fuel shut-off valve is closed and the fuel pump is stopped.</p> <p>The green OK LED blinks, indicating SlowDown</p> <p>This condition will continue, until all of the following parameters are met:</p> <ul style="list-style-type: none"> • Turbine speed less than 800 RPM • EGT is less that 100 degrees C. • The AUX switch is moved to the Off position and throttle trim is moved to the minimum position <p>Once these conditions are met, turbine proceeds to Off.</p>
Manual	<p>ECU in manual mode, with yellow Standby/Manual LED blinking.</p> <p>The fuel valve is opened and the throttle stick controls the fuel pump. (See page 22 for details).</p>
SpeedCtrl	<p>Speed Control mode -- only active when the air speed sensor is connected. Regulates model flight speed.</p>

Explanation for Turbine Shut Down

In the run menu, state selection, are the following explanations for the last shut down condition of the turbine.

Value	Explanation
Manual	AUX switched to Off position or throttle stick and throttle trim moved to the minimum position.
OverTemp	Turbine running over temperature.
IgnTimOut	Turbine did not ignite within programmed time interval.
AccTimOut	Turbine achieved ignition, but did not accelerate within programmed time interval.
Acc. Slow	Turbine achieved ignition, but acceleration was less than the programmed value, during startup.
Over-RPM	Turbine exceeded the maximum RPM, by 5%.
Low-RPM	Turbine running under the minimum RPM, by 10%. Usually triggered by a flame out.
BattryLow	Battery pack dead. Cell voltage is < 1.0V.
HiTempOff	EGT exceeded the maximum range (~950 °C).
Auto-Off	Turbine shut down via the AutoOff sequence, using the AUX channel.
LowTemp	EGT dropped below the minimum value. A dislodged EGT sensor can trigger this shut down.
GlowPlug!	Defective glow plug.

Ground Support Unit (GSU)

The GSU serves as a terminal for displaying and programming parameters. It may be connected or disconnected at any time. The real time nature of the ECU allows the operator to adjust the turbine's parameters, even when the turbine is running.

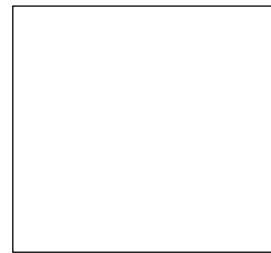

turbine
The real

GSU Control Panel Descriptions

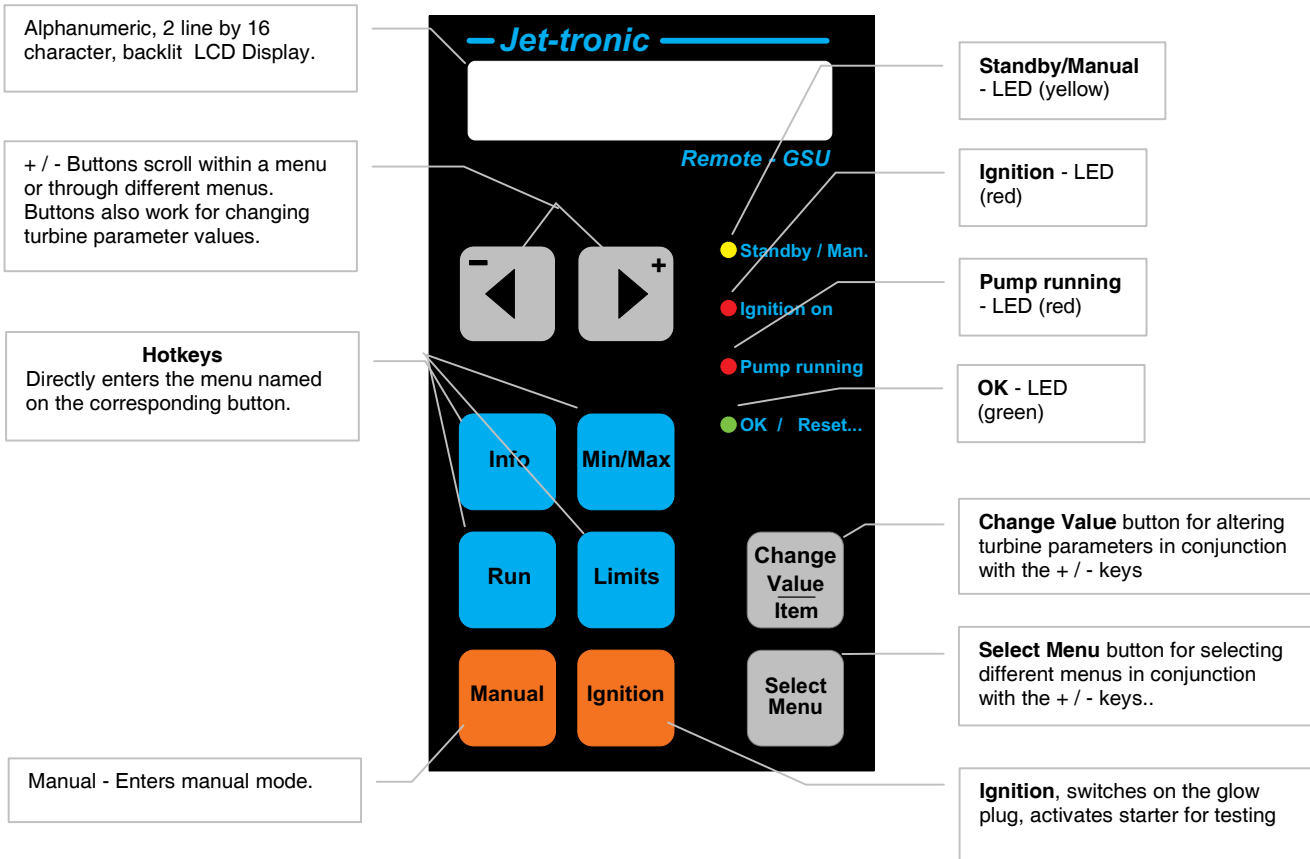

GSU Switch Descriptions

Button	Meaning
Info	Directly displays the Info menu (Hotkey).
Run	Directly displays the Run menu (Hotkey).
Limits	Directly displays the Limits menu (Hotkey).
Min/Max	Directly displays the Min/Max menu (Hotkey).
Select Menu	When the Select Menu button is pressed and held, the + / - buttons are used to select another menu. When a desired menu is reached, release the Select Menu button, and your selection becomes the currently displayed menu.
Change Value/Item	When the Change Value/Item button is pressed and held, the + / - buttons are used to change the indicated value. If the value is admissible to change, a small arrow appears in the display before the value. If the indicated value cannot be changed (e.g.: current RPM or temperature), the display will indicate that the "Value/Item cannot be changed".

GSU LED Descriptions

Color	Name	LED On	LED Blinks
Yellow	Standby/Man.	Starter Motor engaged	Manual Mode is active
Red	Ignition On	Glow Plug is on	---
Red	Pump Running	Fuel pump is on	Glow Plug is defective
Green	OK / Reset...	Turbine running: throttle control active	<ol style="list-style-type: none"> 1. If the turbine is running, the EGT is exceeding the maximum temperature. 2. If the turbine is off, SlowDown mode active

Special function:

If the yellow **Standby/Manual** and green **OK** LED's blink simultaneously, the battery is low and must be recharged.

Menu Structure

All similar data and running parameters are grouped in separate menus. Menus can be displayed and their values modified (where accessible), by using the GSU.

Menu Selections

- Run menu
- MIN/MAX menu
- RC-Check menu
- Info menu
- STATISTICS menu
- Limits menu

Selecting a Menu

The corresponding buttons (hot keys) can directly select the “Run”, “Info”, “MIN/MAX”, or “Limits” menus. An alternate method is to press and hold the **Select Menu** button and use the **+ / -** buttons for selecting. **Note:** this method is the only access to all menus.

Change Values / Items

In order to change an indicated value, press and hold the **Change Value/Item** button while using the **+ / -** buttons to alter its value. An arrow (→) will appear in front of the value, if it can be changed.

The RUN Menu

As soon as the ECU is switched on, the **Run** menu is displayed.

In the lower display line, the actual turbine RPM is indicated.

In the upper display line, the following selections can be monitored. Use the **+ / -** buttons alone for selecting the different parameters.

Value	Explanation
Temp.	Current EGT (E xhaust G as T emperature). The units, °C or °F can be selected in the LIMITs menu.
OffCnd SetRpm	Last Off command (reason for shut down). See table on page 28.
State	Current turbine state.
U-Pump	Current pump voltage.

The Min/Max Menu

The Min/Max menu is used primarily for diagnostics purposes. All of the following variables may be sampled manually by pressing the **Change Value/Item** button on the GSU.

Value	Explanation
Upump-Max Upump-Min	Maximum pump voltage. Minimum pump voltage.
MaxTemp MinTemp	Maximum EGT. Minimum EGT.
MaxRpm MinRpm	Maximum turbine RPM. Minimum turbine RPM.

The R/C Check Menu

All parameters in this menu are for informational purposes only and will vary in accordance with R/C input.

Value	Explanation
Throttle% StickPulse	Position of the throttle stick (by percentage, 0-100%). Position units of the throttle stick.
AuxInp% AuxPulse	Position of the 3-position AUX channel (by percentage, 0-100%). Position units of the AUX channel.
Aux.Position	Position of the AUX channel control (0= Off ; 1= Start/Standby ; 2= AutoOff).

The INFO Menu

Info menu displays the following information:

Value	Explanation
Rest Fuel	Remaining fuel in tank. Tank size can be entered using the LIMITs menu. Value is reset every time the ECU is switched on (or can be reset manually by pressing the Change Value/Item button on the GSU).
Fuel Flow ml/min	Actual fuel consumption in ml/min.
BattCnd	The condition of the battery is indicated in the upper line: <ol style="list-style-type: none"> 1. --OK-- 2. !WEAK! 3. --EMPTY-- <ol style="list-style-type: none"> 1. If the battery voltage is 1.1V/Cell or higher "—OK--" will be displayed. 2. If the battery voltage drops under 1.1V/Cell, the display will read "!WEAK!". Red Standby/Manual and green OK LED's will blink simultaneously (at a rate of twice per second). Starting the turbine is not possible, until the battery is recharged. If the turbine is already running and the battery warning function is enabled, the warning function will be activated. 3. If the battery voltage drops under 1.0V/Cell "—EMPTY--" is displayed. Starting the turbine is not possible until the battery is recharged. If the turbine is running, it will be immediately shut off, to avoid a malfunction of the ECU.
Ubattery	Current voltage of the battery. Displayed on bottom line.
Last Run Time	Last turbine run time.
Last Fuel Count	Quantity of fuel consumed, during the last turbine run.
Last-Off PmpVolt	Volts applied to the pump when it was switched off.
Last Off RPM	RPM of the turbine, when it was switched off.
Last Off TEMP	Temperature of the turbine, when it was switched off.
Last Off Cond	Last stored Off condition.

The Statistic-Menu

Menu parameters are for informational purposes only and cannot be changed.

Value	Explanation
Totl Run-Time	Total turbine running time (excluding startups).
Runs-OK	Number of successful turbine runs, without errors.
Runs aborted	Number of turbine shut downs, caused by the ECU's safety system.
Ignitions OK	Number of successful ignitions.
Ignitions failed	Number of failed ignitions.
Starts failed	Number of failed starts.

The LIMITs Menu

The LIMITs menu allows the operator to adjust the following parameters of the turbine, within the allowable values, according to the performance requirements of a particular model.

Value	Explanation
Minimum RPM	Turbine idle speed Default = 35000
Maximum RPM	Turbine maximum speed Default = 117000
LowBat Warning	Battery warning function, Enabled/Disabled Default = Enabled (ON)
Fueltank size	Actual capacity of the fuel tank in ml Default = 1500 ml
LowFuel Limit	Remaining fuel in the tank when the fuel warning function activates Default = 250 ml
Fuel checking	Fuel warning function, Enabled/Disabled Default = Disabled (OFF)
GlowPlug Power	Glow plug voltage, The glow plug will glow with the selected voltage when the Change Value/Item button is pressed. Default = 2.1V
Gas Flow	Sets the amount of starting gas that will flow when the turbine is started. The range is from 10 to 100% adjustable in 10% increments. Default = 100%
MinRPM SpdCtrl	Turbine RPM low Limit value in cruise control mode. In airspeed control mode, the turbine RPM will not be set below this limit value. This allows a faster reaction time of the airspeed control loop, if this value is set higher than the idle RPM (@ 50000-60000 RPMs are reasonable values)

LIMITs Menu, continued

AUX Channel Function	Remark	AUX-teaching carried out	Airspeed Control
NOT USED	AUX has no function at all	No	Limiter function remains active
ON, TrbCtrl ON	AUX switch controls: - Turbine (OFF/RUN/AutoOff) - Airspeed control - Smoker valve (if enabled)	Yes	Normal function
ON, TrbCtrl OFF	AUX switch only controls: - Airspeed control - Smoker valve (if enabled)	Yes	Normal function

Smoker Ctrl	Remark	Function	Test Function
DISABLED	Smoker Valve not used, always closed		---
Open if AuxSw=0	Smoker Valve is opened if: (Turbine is running or Mode is in manual) and AUX_Position = 0	Valve opens if AUX is set to the OFF position AUX-Channel Option must be set to Enabled	The function of smoker valve can be tested (toggle AUX Switch on RC transmitter) if the Manual mode is activated and the Manual button is kept pressed upon activation
Open if AuxSw=2	Smoker Valve is opened if: (Turbine is running or Mode is in manual) and AUX_Position = 2	Valve opens is AUX is set to Auto-Off position AUX-Channel Option must be set to Enabled	The function of smoker valve can be tested (toggle AUX Switch on RC transmitter) if the Manual mode is activated and the Manual button is kept pressed upon activation

Smoker valve

The ECU can directly control a smoker valve for injection of smoke fluid (e.g. diesel oil) in the exhaust blast. The smoker valve is of the same type as used for the fuel shut off .(Order No.:61106-00).

The function of the smoker valve can be defined in the "Limits menu"
(Parameter: „SmokerValve Ctrl“)

The possible option for the parameter „SmokerValve Ctr“ are:

Option	Description
DISABLED	The smoker valve is not used, → valve is always closed !
Open if AuxSw=0 (*)	Smoker-valve is opened if the AUX-Switch (3-Pos. switch) is brought into the lower position ("OFF"-Position) <u>and</u> the turbine is running. To be able to use this function it is necessary, that the AUX-channel is activated, this is the parameter „AUX-channel func“ (see below) must not be adjusted to „NOT USED“.
Open if AuxSw=2 (*)	Smoker-valve is opened if the AUX-Switch (3-Pos. switch) is brought into the upper position ("AUTO-OFF"-Position) <u>and</u> the turbine is running. To be able to use this function it is necessary, that the AUX-channel is activated, this is the parameter „AUX-channel func“ (see below) must not be adjusted to „NOT USED“.

(*) The function of the smoker valve can be tested at stand still of the turbine as follows:

Set the Throttle stick to idle and Throttle trim to OFF (otherwise you risk that the fuelpump is started in the next step) for additional safety disconnect the fuel feed to the turbine.
Then press and hold the "Manual" button on the GSU (→ yellow LED is now flashing).
With the AUX switch on the RC-transmitter the smoker valve can now be controlled as defined above.

Connection diagram smokesystem

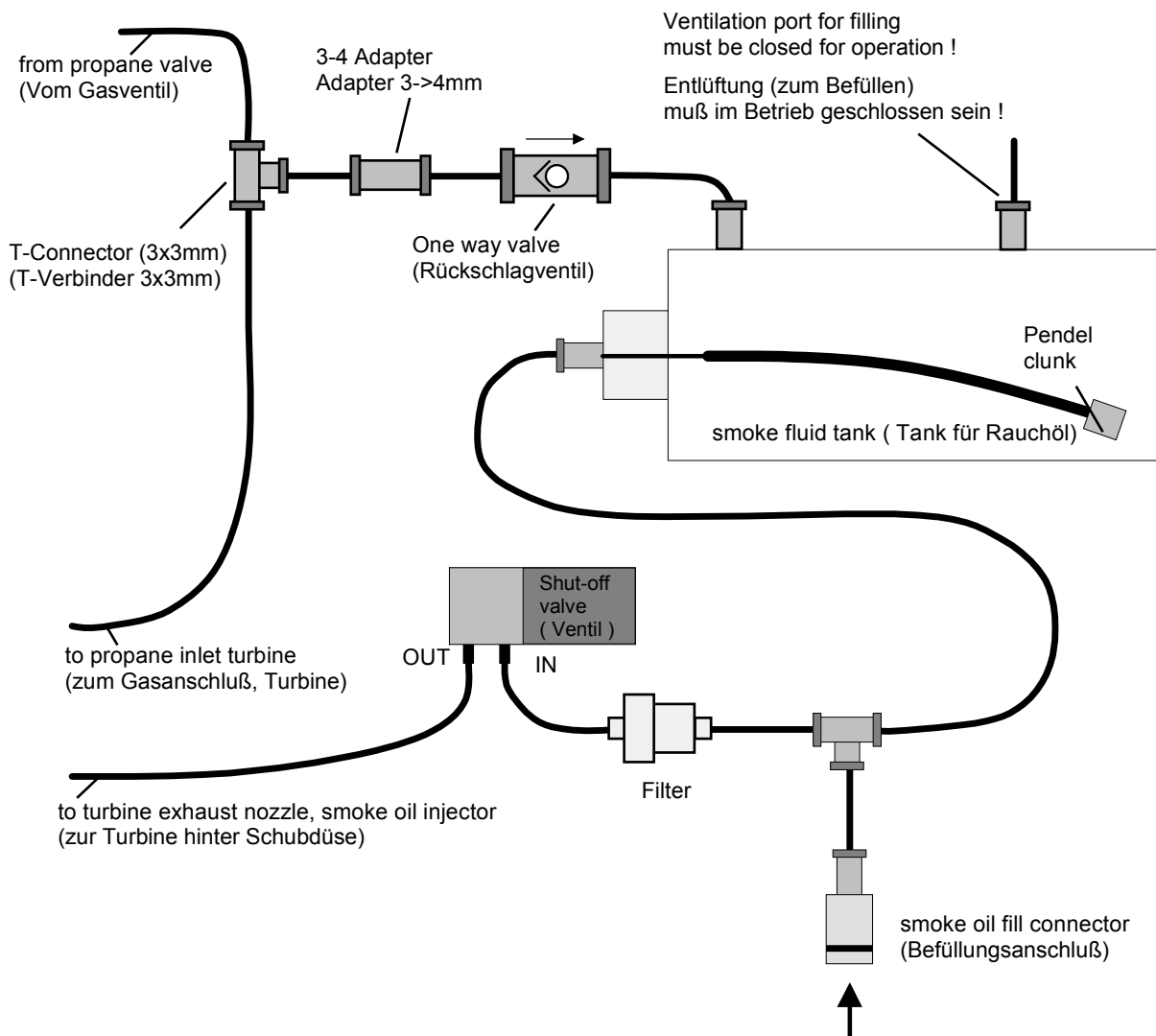

Troubleshooting

Most frequent errors. Cause and remedy:

Problem	Cause	Remedy
Turbine doesn't ignite	<p>Starting gas system has a leak or bad connection.</p> <p>Starting gas pressure is low. May be caused by insufficient quantity of gas or low outside temperatures.</p> <p>Glow plug is not glowing bright enough.</p> <p>Glow plug defective or glow plug element not sufficiently extracted.</p>	<p>Check starting gas system for leaks and poor connections.</p> <p>Fill starting gas tank; fly in warmer conditions (e.g. Southern California)</p> <p>Adjust glow plug voltage. Glow plug must be bright red!</p> <p>Replace defective glow plug. Glow plug element must be extracted by at least 1/8 inch (two coils)! See page 8.</p>
Starting process fails	<p>Turbine is still too warm; Cool Down not yet completed.</p> <p>Low battery or faulty connection.</p> <p>Glow plug defective (red Pump running LED blinks).</p> <p>Three-conductor cable for starter motor and glow plug disconnected.</p>	<p>Wait until SlowDown sequence is finished. The green OK LED will stop blinking.</p> <p>Charge battery. Check ECU's battery connection.</p> <p>Replace defective glow plug.</p> <p>Check cable. Check for proper connection from ECU to the turbine.</p>
ECU doesn't follow full commands from the throttle stick	<p>Programming alteration in R/C transmitter</p>	<p>Check alignment with RC-Check menu. Re-align ECU to the R/C system. See page 19.</p>

Turbine ignites, but the start process is discontinued.	Air in fuel feed lines. Fuel pump not running. Starting gas tank nearly empty.	Air leaks in fuel system. Examine all Festo fittings, nipples, clunk, filter, etc. Check for fuel filter clogs. Test the pump in manual mode (as soon as the red Pump running LED illuminates, the fuel pump must run!). See page 22. Fill starting gas tank.
Starter unit slips, makes noise.	Dust and oil sediment on the compressor nut and O-ring.	Clean O-ring and compressor nut periodically, with cotton swab and solvent.
EGT giving erratic temperature readings.	Transmitter antenna too close to the model.	Keep the antenna away from the model. It may cause false readings.

Maintenance

Occasionally, the starting unit clutch may slip or not grip properly, the result of dust and oil sediment on the compressor nut. The O-ring and compressor nut should be cleaned periodically, with a cotton swab and solvent. When the turbine is not running, the starter may be tested by pressing the **IGNITION** button on the GSU.

Check your fuel filters every ten (10) flights.

Each **JetCAT** has a prescribed maintenance interval. After approximately 25 hours, the engine should be returned to **CAT** (along with the ECU and fuel pump), for service. The total running time of the turbine can be accessed and monitored through the **STATISTIC** menu.

Parts List

- 1 – P80 engine
 - 1 – ECU
 - 1 – GSU
 - 1 – PUMP
 - 1 – Battery Pack
 - 1 – Fuel Valve
 - 1 – Starting Gas Valve
 - 1 – Cable Set
 - 1 – Fuel Line Set
 - 1 – Starting Gas Tank
 - 2 – Quick Disconnects (fuel/starting gas)
 - 3 – Filler Connectors
 - 2 – Fuel / Propane Filter
 - 1 – Fuel Tank Clunk
 - 1 – 4 to 3mm Nipple (at the propane valve)
 - 1 – 4 to 4mm Nipple
 - 1 – “T” Connector
 - 1 – Engine Mount
 - 1 – Manual
- several connectors for tank system

Optional Accessories

- Air Speed Sensor
- RS-232 Adapter
- Exhaust Duct inlet Ring
- Inner Exhaust Duct Material (titanium)
- Outer Exhaust Duct Material (0.5mm Aluminum)
- GFK duct housing
- Engine Mount, Bypass Style
- Engine Mount, Kangaroo Style

Airspeed Sensor

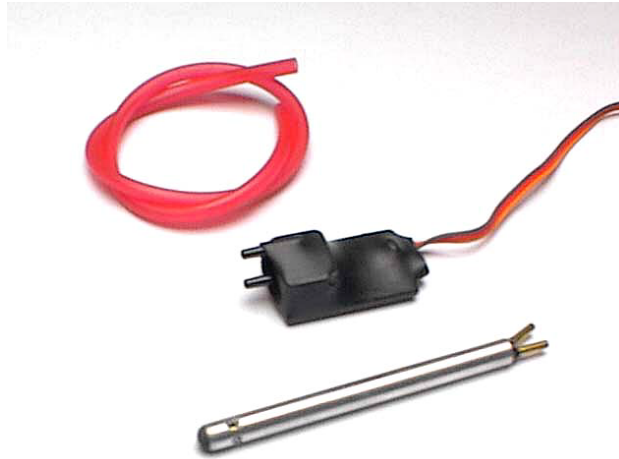

The optional *Airspeed Sensor* consists of a pitot tube and a precision, differential pressure sensor. By sampling the ambient air temperature, the current flight speed of the model is calculated by the ECU, from the measured difference in static versus dynamic pressure.

When the ECU is used without the *Airspeed Sensor*, it is set in **thrust control** (normal) mode. In this mode, the throttle stick directly alters turbine thrust.

When the *Airspeed Sensor* is plugged into the ECU, it automatically establishes **speed control** mode. In **speed control** mode, the turbine thrust is automatically controlled – to keep the model at a predetermined speed and/or to limit the model's maximum speed.

Speed control mode features several functions:

- measurement and storage of maximum and average flight speeds
- automatic restriction of maximum flight speed
- maintenance of current flight speed (fixed "**Cruise Control**")
- regulation of flight speed, analogous to throttle stick position (adjustable "**Cruise Control**")

Connection diagram for the Airspeed Sensor:

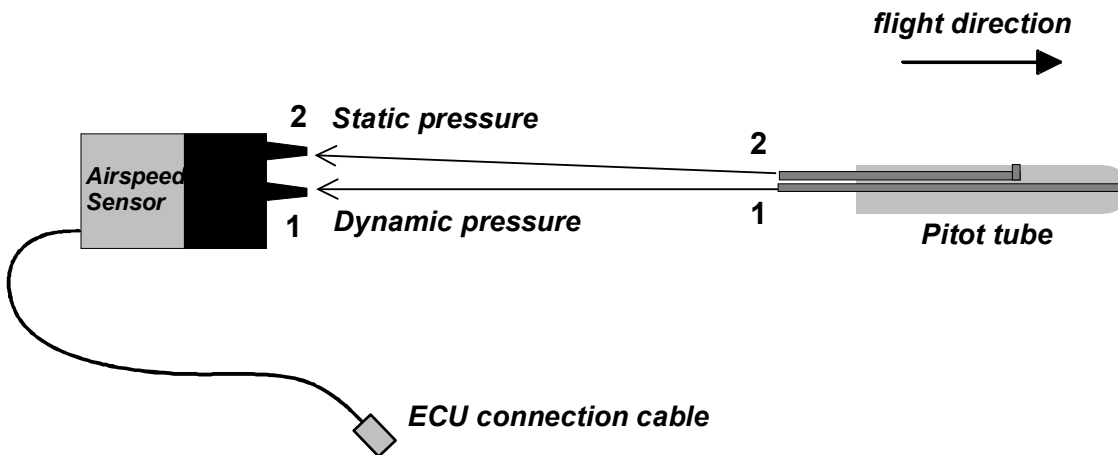

Connect the air lines from the pitot tube to the airspeed sensor, using the 1/16th inch ID vinyl tubing provided.

- 1 = Dynamic pressure input
- 2 = Static pressure input

Note: Tubing length and/or cross sectional area has no influence on measurement precision

Connect the *Airspeed Sensor* cable to the appropriate socket, where indicated on the ECU (see: engine diagram in the Operation Manual). The orange wire is aligned to the pulse symbol. Once the *Airspeed Sensor* is connected, the ECU controls additional functions:

- under the **Run** menu, measurement of current air speed ("**Airspeed**") and desired flight speed ("**SetSpeed**"), can be displayed
- under the **Min/Max** menu, the measured maximum speed ("**MaxAirSpd**") and the average flight speed ("**AvgAirSpd**"), can be displayed
- under the **Limits** menu, speed limits and the parameters of speed regulation can be predetermined

Limits menu parameters assigned to the *Airspeed Sensor*:

Parameter	Explanation
MAX LIMITAIRSPD	Maximum allowed flight speed of the model, in km/h. If this speed is achieved, turbine thrust is automatically reduced – to keep the model from exceeding the maximum limit. This safety option is always active, despite the position of the AUX switch.
Max.AirSpeed	Maximum flight speed value, in km/h, for the Cruise Control mode. This value corresponds to the speed at the maximum throttle stick position.
Min.AirSpeed	Minimum flight speed value, in km/h, for the Cruise Control mode. This value corresponds to the speed at the minimum throttle stick position.
SpeedRegVal-I	Regulator speed, which sets the reaction time of the PID servo loop – much like a sensitivity control in a gyroscope system. Default value = 2 Increase this value, to increase reaction sensitivity.
SpeedRegVal-P	Regulator coefficient (proportional) Default ≥ 500 Under normal circumstances, does not require alteration.
SpeedRegVal-D	Regulator coefficient (differential) Default = 0 Under normal circumstances, does not require alteration.
SPDCTRL SW0 ACT	With the <i>Airspeed Sensor</i> connected to the ECU – by moving the AUX switch to the Off (SW0) position, while maintaining a model air speed > 40km/h, the following options are available: Hold-Speed = momentarily sustains the current flight speed

	DISABLED/NONE = no function, thrust control remains active Turbine OFF = turbine will immediately shut off LrnSpeed Lo/Hi = learn minimum or maximum flight speeds Lrn Speed Lo = learn minimum flight speed Lrn Speed Hi = learn maximum flight speed
SPDCTRL SW2 ACT	With the <i>Airspeed Sensor</i> connected to the ECU – by moving the AUX switch to the AutoOff (SW2) position, while maintaining a model air speed > 40km/h, the following options are available: Hold-Speed = momentarily sustains the current flight speed DISABLED/NONE = no function, thrust control remains active LIN-Speed Ctrl = linear Cruise Control 3-StepSpdCtrl = three speed Cruise Control

Explanation of the speed regulator options:

If the *Airspeed Sensor* is NOT connected – the standard functions of the **AUX** switch are assigned as follows:

Standard assignments of the **AUX** switch:

- **Position SW0** = **Off**, turns the turbine off, immediately
- **Position SW1** = **Start/Standby**, normal **thrust control**
- **Position SW2** = **AutoOff**, normal shutdown method

With the *Airspeed Sensor* connected to the ECU, the **AUX** switch positions **SW0** and **SW2** include the expanded functions that are covered in the above parameters table. These expanded assignments are only valid when the model is airborne (with a flight speed > 40 km/h), otherwise the standard functions remain active.

As long as the **AUX** switch is maintained in the center position, the ECU continues functioning in **thrust control** mode and turbine thrust can only be determined by the throttle stick position.

Available options:

Option	Description
Hold-Speed	<p>Maintains the current flight speed. Flight speed is measured at the time the AUX switch is placed in the SW0 position. This action establishes the ECU in speed control mode (i.e.: the model maintains the flight speed measured at the time the mode is activated, despite the throttle stick position). This mode remains active until the AUX switch is returned to the SW1 position.</p> <p>WARNING: When the AUX switch is set in the SW0 position, the model must be flying faster than 40 km/h, otherwise the turbine will shut off.</p>
DISABLED/NONE	No function. Thrust control mode remains active.
Turbine OFF	Immediately shuts down turbine. Normal thrust control mode remains active.
LrnSpeed Lo/Hi	<p>Learns the current flight speed. If the throttle stick is set at less than half throttle and the AUX switch is momentarily placed in the SW0 position, the current flight speed is assigned and recorded as the Min.AirSpeed parameter. If the throttle stick is set at greater than half throttle and the AUX switch is momentarily placed in the SW0 position, the current flight speed is assigned and recorded as the Max.AirSpeed parameter. By momentarily activating the AUX switch, this option makes it possible to store a particular slow or fast model speed, while in flight. These values then become the parameters for the Cruise Control mode, plus the operator can also display the values in the limits menu, after landing.</p> <p>WARNING: When the AUX switch is set in the SW0 position, the model must be flying faster than 40 km/h, otherwise the turbine will shut off.</p>

Lrn Speed Lo	Learns the slow flight speed. If the AUX switch is momentarily placed in the SW0 position, the current flight speed is assigned and recorded as the Min.AirSpeed parameter. WARNING: When the AUX switch is set in the SW0 position, the model must be flying faster than 40 km/h, otherwise the turbine will shut off.
Lrn Speed Hi	Learn the fast flight speed. If the AUX switch is momentarily placed in the SW0 position, the current flight speed is assigned and recorded as the Max.AirSpeed parameter. WARNING: When the AUX switch is set in the SW0 position, the model must be flying faster than 40 km/h, otherwise the turbine will shut off.
LIN-Speed Ctrl	Cruise Control mode, with linear speed regulation to the throttle stick position. Flight speed is controlled between the values of the “Min AirSpeed” (throttle stick in the minimum position) and “Max AirSpeed” (throttle stick in the maximum position).
3-StepSpdCtrl	Cruise Control mode, featuring three different speeds. Flight speed can be set to three predetermined speeds, between the values of “Min AirSpeed” (throttle stick in the minimum position) and “Max AirSpeed” (throttle stick in the maximum position). Speed 1: “Min AirSpeed” → throttle stick in the minimum to 1/3 rd position Speed 2: (“Min AirSpeed” + “Max AirSpeed”) / 2 → throttle stick in the 1/3 rd to 2/3 rd position Speed 3: “Max AirSpeed” → throttle stick in the 2/3 rd to maximum position

Reminder:

The turbine can be immediately switched off, any time the throttle stick and the throttle trim are brought to their minimum positions.

If **Hold-Speed** or **Cruise Control** modes are activated, while the model is flying over 40 km/h -- and should the model then slow down, to a speed less than 40 km/h -- **Hold-Speed** or **Cruise Control** *will remain active*. The turbine will NOT shut off, unless the **AUX** switch is moved back to the **SW1** position and then returned to **Hold-Speed** or **Cruise Control** position.

WARNING:

Make sure the *Airspeed Sensor* is working, before using features that require a minimum flight speed to operate. If the system is not operating properly, you may inadvertently shut off your engine, in flight. To verify that the *Airspeed Sensor* is functioning, apply a little air pressure and note the change in “**Airspeed**” on the **run** menu display.

Two examples:

Example 1 – Hold-Speed function

SpdCtrl SW0 Act assigned to “**Hold-Speed**” and **AUX** switch set in the **SW0** position:

- a) Flight speed is measured and stored, when the **AUX** switch is moved to the **SW0** position. Thrust is then regulated automatically, to maintain this memorized speed, despite the throttle stick position. This regulator function is turned off immediately, by returning the **AUX** switch to the **SW1** position (normal **thrust control**).
- b) If this function is activated while flight speed < 40 km/h, turbine will shut off, immediately (normal **Off** function).

Example 2 – Linear speed regulation

SpdCtrl SW2 Act assigned to “**Lin-SpeedCtrl**” and **AUX** switch set in the **SW2** position:

Cruise Control mode becomes active, featuring linear speed regulation to the throttle stick position.

- a) The minimum throttle stick position corresponds to the parameter “Min AirSpeed” and the maximum throttle stick position corresponds to the parameter “Max AirSpeed”.
- b) If flight speed < 40 km/h when this function is activated, the turbine will shut off (normal **AutoOff** function).

Airspeed Sensor Mounting:

Experiments indicate that the *Airspeed Sensor* is more accurate when the pitot tube is side-mounted on the widest part of the fuselage. In this configuration, the pitot tube should stand off from the fuselage, by at least two (2) inches. Because each model installation is different, JetCAT will have additional mounting information for review, as auxiliary data becomes available.

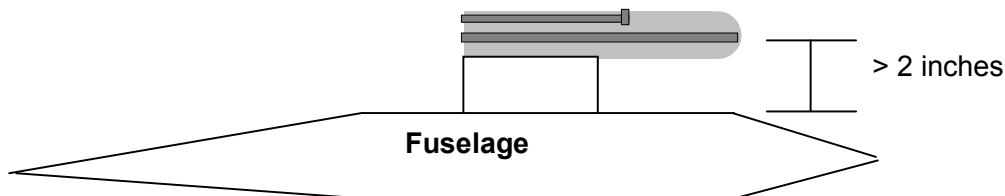

Hold Speed and Cruise Control limitations:

Under normal circumstances, the *Airspeed Sensor* is primarily used for limiting the maximum flight speed and/or recording the maximum and average speeds of the model. Nonetheless, **Hold Speed** and **Cruise Control** modes are clever additions. These modes require evaluating and adjusting the PID parameters in the **limits** menu, while flying the model with a different technique. The slower reaction time of the throttle response necessitates executing smoother patterns, with limited pitch changes. Experimenting will identify how the turbine will react and help ascertain how to compensate for its limitations.

Ducting

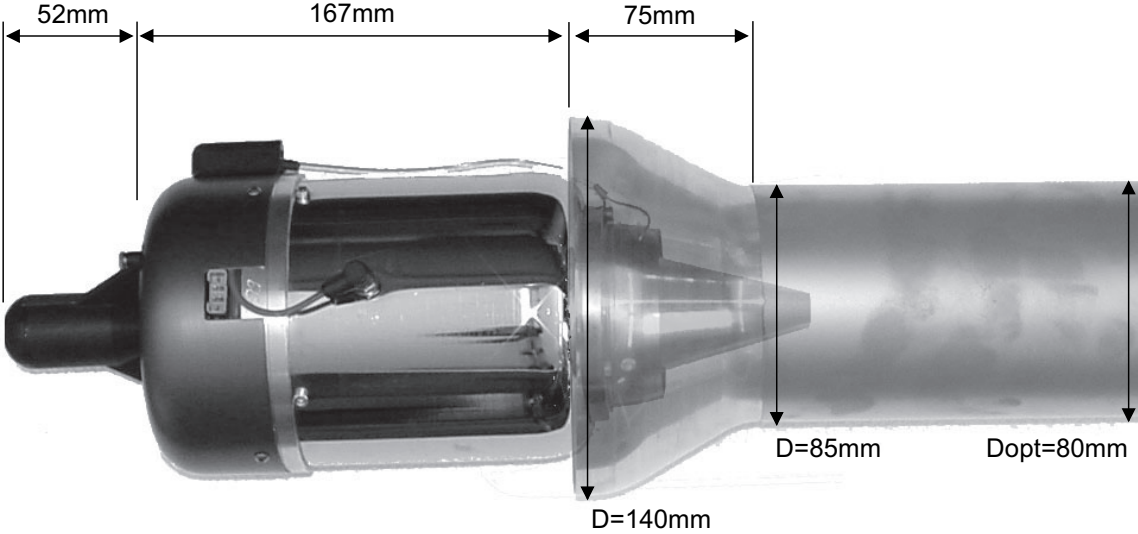

Price List Model Jet Engines and Accessories

<i>Picture</i>	<i>Connections</i>	<i>DESCRIPTION</i>	<i>Order no.</i>	<i>Recommended Enduser retail price / € net*</i>
		Model Jet Engines Set P 60 "D"	71111-00	1.950,00
		Model Jet Engines Set P 70 "D"	71112-00	2.396,50
		Model Jet Engines Set P 80 "D"	71100-00	2.556,50
		Model Jet Engines Set P 120 "D"	71114-00	3.042,50
		Model Jet Engines Set P 160 "D"	71118-00	3.306,--
		Model Jet Engines Set P 180 "D"	71116-00	3.663,80
		Model Jet Engines Set P 200 "D"	71117-00	4.055,--
		Heli Turbine PHT 3	71133-00	3.450,--
		Heli Turbine PHT 4	71136-00	3.150,--
		Turboprob Turbine SPT5	71138-00	4.225,--

		2-Shaft-Helicopter-Engine SPH5	71139-00	4.000,--
		Festo Connecting Set (PHT3) - Festo quick connector QSM-4 - Quick connector QSMY-4 (PHT3-Set) - Festo plug & screw QSMF-M5-4 - Coupling 20/ Coupling KD2M5A - Festo Connector KS-PK-3-M5 - Fitting tube N-M5-PK-4 - Filter Typ F-30/CAT modif. (Satz) (Turb) - O-Ring Ø 12 x 2 VI500(Filter-Turb) - Fest silencer U-PK-4 - Special tunk clunk	61127-00 Consisting of: 21105-01 21127-01 21105-02 21105-03 21105-04 21105-05 21105-08 21105-10 21105-07 21105-09	79,60
	4mm → 4mm 4mm → 3mm 3mm → 3mm	Quick connector	21105-01 21105-06 21105-30	2,60 2,70 2,30
	M5 (inside) → 4mm	Quick connector M5 thread	21105-02	2,45
	3 x 4mm	T- Quick connector	21100-28	5,35
		Self shutting connector (female) (fitting to 21105-04 / 21105-02)	21105-03	9,20
		Male part for 21105-03	21105-04	2,30

		Special tank clunk	21105-09	11,25
	4mm Ø outside 2.5mm Ø inside	Fuel tubing 4mm transparent, PVC 2.5mm i. Ø	21100-15	1,70/ Meter
	3mm Ø outside	tubing 3mm, PUN Ø3x0.5 (gas tubing)	21104-01	1,30 / Meter
		Set of tubing: 5m fuel tubing (4mm), 2m gas tubing (3mm)	61104-00	11,25
	M5	Fitting, e.g. for fuel tank	21105-05	1,10
		Propane / Fuel - filter	21105-08	14,10
		Festo quick connector set (self shutting)	Consists of: 21105-03 21105-04 21105-02	14,10
		Quick Connector cpl. P80 / P120 / P160 Consisting of: 2x Filter 1x Special tank clunk 2x Quick Connector 3x Connector (male part) 1x 4→4 Quick Connector 1x 4→3 Quick Connector 1x T-connector 4mm 2x tank fittings	61105-00 21105-08 21105-09 21105-03 21105-04 21105-02 21105-04 21105-01 21105-06 21100-28 21105-05 21105-02	71,60

		Fuel pump 6VDC, 65g complete with cable and connector	31100-03	115,10
		Fuel pump P200		122,00
		Shut off valve for fuel / propane	61106-00	58,80
		Starter gas tank	21100-26	7,45
	Suitable for JetCat P80 / P120	Turbine mount standard		17,90
	Suitable for JetCat P80 / P120	Turbine mount for „Kangaroo“ pink anodised	61124-00	28,15
	Suitable for JetCat JetCat P80 / P120	Turbine mount for „HotSpot“ pink anodised		28,15
	Direct ECU connection	Air-Speed-Sensor with pitot tube	61120-00	101,25
		RS232-Adaptor + Software	61109-00	79,90
		LED-I / O board	61108-00	19,95
		Warn - LED	61165-00	
		GSU	61101-00	120,15

		ECU, control electronics ECU, control electronics in housing	61102-00	235,20 241,55
		Electrical Cable Set P80 / P120 cpl. 3 x Busconnection cable 3-wire Powercable	61103-00	20,45
		Sanyo NiCad battery 6 cells / 1250 mAh 60 cm cable	31100-04 31133-03	28,15 38,50
		Turbine installation kit P80 / 120 / 160 Consisting of: 1x ECU 1x LED I/O board 1x Electrical Cable Set 2x Shut off valve 1x Starter gas tank 1x NiCad battery 1x fuel pump 1x Turbine mount standard 1x fuel plumbing set 1x Set of tubing	71105-00 P80 71106-00 P120 71107-00 P160	603,35
		Turbine installations kit P200		612,--
		Exhaust ducting Material: Titan Inlet cone: Aluminium Material: V2A Inlet cone: Aluminium	61121-00	21,-- + 1,50 / cm 21,-- + 1,50 / cm
		JetCat GPS-Empfänger, to interface on ECU's Softwareversion 4.00h or upgrade	10	245,--

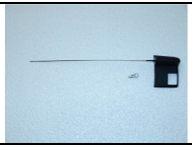
		Dimension: 60 x 42 x 20		
		JetNet	61128-00	25,--
		Temp. Sensor	51100-03	25,--
		Datalink Groundstation	61128-00	395,--
		Datalink ECU-Receiver		395,--

* plus VAT